



 **STOCK**
SWEEPERS





1998 - From Humble Beginnings

Stock Sweepers was founded in 1998. Our family business was created to recondition and remount used road sweeping equipment onto new chassis, specifically for our own operated hire fleet. Word about our work spread fast, and quickly the business grew into the UK's premier company for remounting truck mounted sweepers.

2009 - Into a New Era

10 long years of dismantling and rebuilding worn sweeping equipment taught us many things about road sweepers. We learnt that there were common weaknesses found on many of the existing machines available on the market. We believed that one day we could overcome these weaknesses, and that we could build a better, longer-lasting machine with a much greater life span than the existing manufacturers.

In 2009, we launched two new robust sweepers: the S6400 and S8400. Utilising the latest British road sweeping technologies available to us, and remaining focused on maximum life span, we used top quality components to make sure our machines were designed to last up to 20 years with regular care and sensible maintenance.

Today

Our sweepers are now available in many different countries in North America, Asia, Australia, and Europe. We remain true to our vision, which is building quality machines that have the longest working life achievable and minimum down time for our customers. Our mission will never be to sell the most number of sweepers; it's to build the best sweeper possible.



Our Road Sweepers Are Work Tools

Having operated our own fleet of road sweepers for years, we truly understand how important it is to have reliable machines. Maximum utilisation is at the heart of a Stock Sweeper; we make sure the operator can get the maximum work time possible from any of our machines. Robust, modern engineering ensures our customers are road sweeping for the maximum time possible.

Ease of Operation - Intelligent Sweep System (iSS)

We employ the simplest and most reliable operator-friendly controls to operate our machines. Technology is a fast-moving business, and we only utilise robust, well-tested systems to manage our sweepers.

CANbus Operating Control System - 5 Year Warranty

Our operating software is the heart of our machines. We are so confident in its ability, it comes with a five year warranty.

S6400 and S8400 Sweepers - 12 Month Warranty

All of our machines come with a comprehensive twelve month warranty. A copy of our terms and conditions is available on request.

Made in England

Our machines are designed and manufactured in England. We are proud to be a British-owned manufacturing company.

S6400 OVERVIEW



What You Need to Know

Truck Chassis: 15-18 tonnes GVW

Hopper: 6.5m³ with Twin-Discharge System (Electric and PTO Operation)

Sweep Format: · Dual Side Sweep (Left and Right) with Wide Sweep 'Belly' Brush and Dual-Suction Nozzles. **Dual-Sweep Recommended*

· Single Side Sweep (Left or Right) Also Available.

· Overhead Wander Hose 4.2m Reach Available, 150mm and 200mm, Manual or Hydraulically-operated. **150mm Recommended*

Sweep Path: Max 3,650mm.

Sweep Speed: 2 to 16kph.

CANbus Intelligent Sweep System: Operator-friendly electronic controls.

JCB Auxiliary Engine: A choice of 68kW or 93kW engines.

Auxiliary Fuel Tank: 160 Litres.

Clean Water Tank: 1600 Litres.

Low Pressure Dust Suppression Water System: 35 litres/min at 3.5 bar (50 PSI).

High Pressure Wash Water System: 30 litres/min at 150 bar (2200 PSI).

Service intervals: 500 hours.

Built to Last

The S6400 has been designed to last as long as possible. The mild and stainless steel components that we use are thicker than the road sweeper industry standard, to ensure the longest life span achievable. All equipment is precision fabricated, then powder-primed and coated, to give an extremely durable and high quality finish.



6.5m³ Capacity

Standard twin-discharge system comes with every Stock Sweeper. Should the auxiliary engine PTO (power take-off) fail, our equipment has its own independent electrical discharge system for additional use, if needed.

Body, Cowl and Rear Door - Stainless Steel

The body, cowl, and rear door are fully built with corrosion and abrasion-resistant stainless steel.

1600L of Clean Water

1600L as standard, with optional 250L - 4000L additional water tanks available. *Chassis dependant

Double-Strength Subframe and Tipping Hinges

We know our sweepers have to be robust, and critical to the stability of the vehicle is its subframe and tipping hinges. Twice the typical steel is used, to ensure maximum stability on uneven ground.

S6400 AUXILIARY ENGINE



JCB 68kW

Maximum Rating (Gross Intermittent)	68kW (91hp)
At Speed	2200 rpm
Peak Torque	433 Nm (319 lb-ft)
Peak Torque Speed	1500 rpm
Maximum No Load Governed Speed	2450 rpm
Nominal Idling Speed	850 rpm
Thermodynamic Cycle	Diesel 4 Stroke
Air Intake	TCA
Arrangement	4.4L
Nominal Bore	103mm (4.06")
Stroke	132mm (5.20")

JCB 93kW

Maximum Rating (Gross Intermittent)	93kW (125hp)
At Speed	2200 rpm
Peak Torque	525 Nm (387 lb-ft)
Peak Torque Speed	1300 rpm
Maximum No Load Governed Speed	2390 rpm
Nominal Idling Speed	800 rpm
Thermodynamic Cycle	Diesel 4 Stroke
Air Intake	TCA
Arrangement	4.4L
Nominal Bore	103mm (4.06")
Stroke	132mm (5.20")

S6400 SWEEP PATH

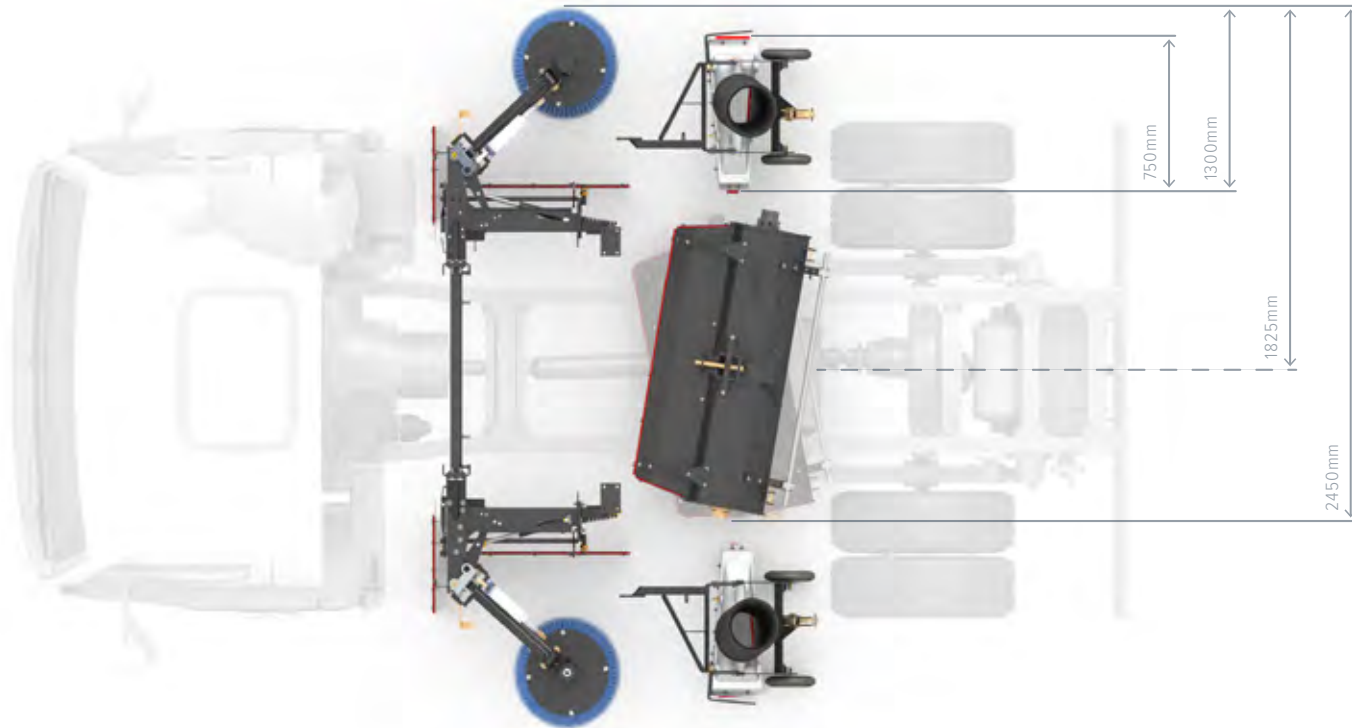

Side Brush

The side brush equipment is of a heavy-duty construction, and has brush speed control with 'power-down' ground pressure regulation fitted as standard. The 'power-down' feature enables the operator to scrub the road harder, to remove run-in and compacted dirt. The side brushes have fully adjustable sideways positioning and variable side brush rotation to ensure you sweep efficiently, even in awkward situations. The S6400 has an impressive overall sweep width of 3650mm and allows the S6400 to clean many roads in a single pass. At the push of a button, the curb-top sweep function can be utilised in tight or difficult situations.

Wide Sweep Brush

The 400mm-diameter by 1300mm-long wide sweep brush has a fully adjustable ground pressure regulation system. The system is set on four regulators (two for left-hand sweeping and two for right-hand sweeping). This enables the operator to switch from left to right-hand sweeping operations without the need to leave the cab of the vehicle and readjust the brush. Fitted with 'power-down' the wide sweep brushes performs efficiently on run-in and stubborn compacted dirt. The wide sweep brush canopy and guards are robustly constructed from 4mm powder-primed and powder-coated mild steel, ensuring maximum life expectancy.

Unique to our sweepers is our one-touch left-to-right sweep control system.

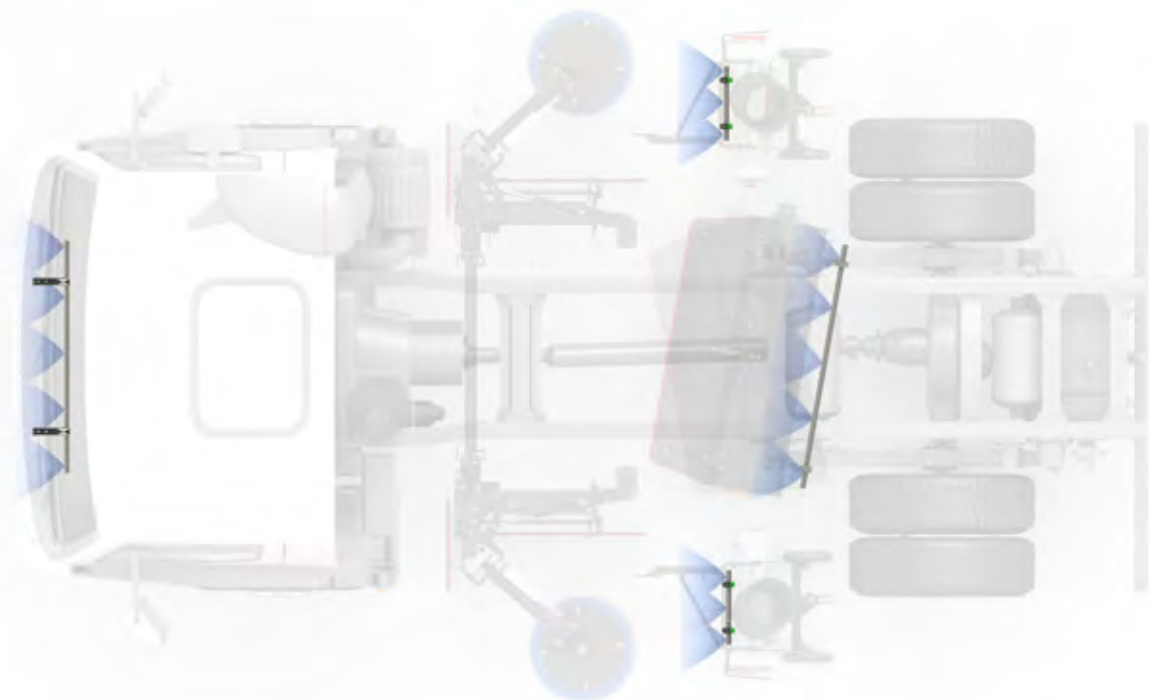

Dust Suppression System

The self-priming, low-pressure water dust suppression pump ensures dust-free collection of all swept material. Water can be injected directly into the suction box, towards the side brush, and across the front of the vehicle. The dust suppression system delivers 35 litres/min at 3.5 bar (50 psi).

High Pressure Wash

For more arduous cleaning the high pressure water system incorporates a hand lance with 15 metres of hose, suction box spray bars, and wide sweep brush spray bar all delivering water at up to 30 litres/min at 150 bar (2,200 psi) precisely where it's needed.



Nozzle Suction

The suction boxes are constructed of cast aluminium with a 4mm moulded vulcanized wear-resistant rubber lining. Each of the two boxes can be raised or lowered, and be tilted backwards at the flick of a switch, to make the pick-up of larger material effortless.

Overhead Suction

The overhead wander hose has a 4.2 metre reach that can be used for many operations; from cleaning catch-pits and road gullies, to picking litter and leaf collection. To ensure the wander hose does not become too heavy in operation, it is fitted with a counter-balancing spring system. The overhead wanderhose can also be hydraulically operated.

Screen Shakers 'Healthy Airflow'

Rear mesh screen shakers are another standard fitment. They enable the operator to clean the rear screens every time the rear door is opened, both screens are lowered automatically making thorough washing of the screens an easy task. This is essential to maximise the sweepers suction and will minimise unnecessary engine and equipment wear. The screens can also be operated with the rear door closed using the 'quick clean' function. This is done by unclipping the handle and pulling down sharply on the rear cables, to shake the screens free from dirt and leaf build-up.



CANbus Operating System

The S6400's equipment is activated via an operator's electronic CANbus control panel, which has been designed and installed with operator ergonomics in mind. The easy-to-use panel allows the operator to set their preferred settings, which are then activated by one-touch operation on the iSweep system, mounted near the driver's door.

iSweep

The touch sensitive control panel is conveniently mounted near the operator's side window, helping to reduce the level of distraction to the operator to an absolute minimum. Full control simply rests at the operators finger tips.

Performance and Diagnostics

Our CANbus system monitors sweeping and auxiliary engine performance. It has full diagnostics to aid operators and technicians, perform routine checks, maintenance, and repairs.

'TEMPEST' LEAF BLOWER



Leaf Blowing System

Our patented leaf blowing system is the most effective method of removing leaves in rural/semi-rural conditions. It blows leaves off roads and footpaths into verges in one pass, by cleverly using the sweeper vacuum exhaust air, blowing it out from under the front of the chassis cab. Full electric control allows you to adjust the air jet angle to right where you need it. It reduces non-productive off-site time and has considerable fuel and environmental savings by eliminating needless journeys to landfill sites.

Leaf Blowing System - Wander Hose

The hand blowing wander hose attachment reaches into corners and difficult areas where leaves cannot be blown away. The handheld blower attachment enables the operator to blow them into the road, where they can be swept up conventionally by the sweeper.

S8400 OVERVIEW



What You Need to Know

Truck Chassis: 18 tonnes GVW

Hopper: 8.4m³ with Twin-Discharge System (Electric and PTO Operation)

Sweep Format: · Dual Side Sweep (Left and Right) with Wide Sweep 'Belly' Brush and Dual-Suction Nozzles. **Dual-Sweep Recommended*
· Single Side Sweep (Left or Right) Also Available.
· Overhead Wander Hose 4.2m Reach Available, 150mm and 200mm, Manual or Hydraulically-operated. **150mm Recommended*

Sweep Path: Max 3,650mm.

Sweep Speed: 2 to 16kph.

CANbus Intelligent Sweep System: Operator-friendly electronic controls.

JCB Auxiliary Engine: A choice of 68kW or 93kW engines.

Auxiliary Fuel Tank: 160 Litres.

Clean Water Tank: 2100 Litres.

Low Pressure Dust Suppression Water System: 35 litres/min at 3.5 bar (50 PSI).

High Pressure Wash Water System: 30 litres/min at 150 bar (2200 PSI).

Service intervals: 500 hours.

Heavy-Duty and Built to Last

The S8400 has been designed to last as long as possible, with the advantage of extended operating hours - it works harder, for longer. The mild and stainless steel components that we use are thicker than the road sweeper industry standard, to ensure the longest life span achievable. All equipment is precision fabricated, then powder-primed and coated, to give an extremely durable and quality finish.



8.4m³ Capacity

Standard twin-discharge system comes with every Stock sweeper. Should the auxiliary engine P.T.O. fail, our equipment has its independent electrical discharge system for additional use, if needed.

Body, Cowl and Rear Door - Stainless Steel

The body, cowl, and rear door are fully built with corrosion and abrasion-resistant stainless steel.

2100L of Clean Water

2100L as standard, with optional 250L - 4000L additional water tanks available. *Chassis dependant

Double-Strength Subframe and Tipping Hinges

We know our sweepers have to be robust, and critical to the stability of the vehicle is its subframe and tipping hinges. Twice the typical steel is used to ensure maximum stability on uneven ground.

S8400 AUXILIARY ENGINE



JCB 68kW

Maximum Rating (Gross Intermittent)	68kW (91hp)
At Speed	2200 rpm
Peak Torque	433 Nm (319 lb-ft)
Peak Torque Speed	1500 rpm
Maximum No Load Governed Speed	2450 rpm
Nominal Idling Speed	850 rpm
Thermodynamic Cycle	Diesel 4 Stroke
Air Intake	TCA
Arrangement	4.4L
Nominal Bore	103mm (4.06")
Stroke	132mm (5.20")

JCB 93kW

Maximum Rating (Gross Intermittent)	93kW (125hp)
At Speed	2200 rpm
Peak Torque	525 Nm (387 lb-ft)
Peak Torque Speed	1300 rpm
Maximum No Load Governed Speed	2390 rpm
Nominal Idling Speed	800 rpm
Thermodynamic Cycle	Diesel 4 Stroke
Air Intake	TCA
Arrangement	4.4L
Nominal Bore	103mm (4.06")
Stroke	132mm (5.20")

S8400 SWEEP PATH

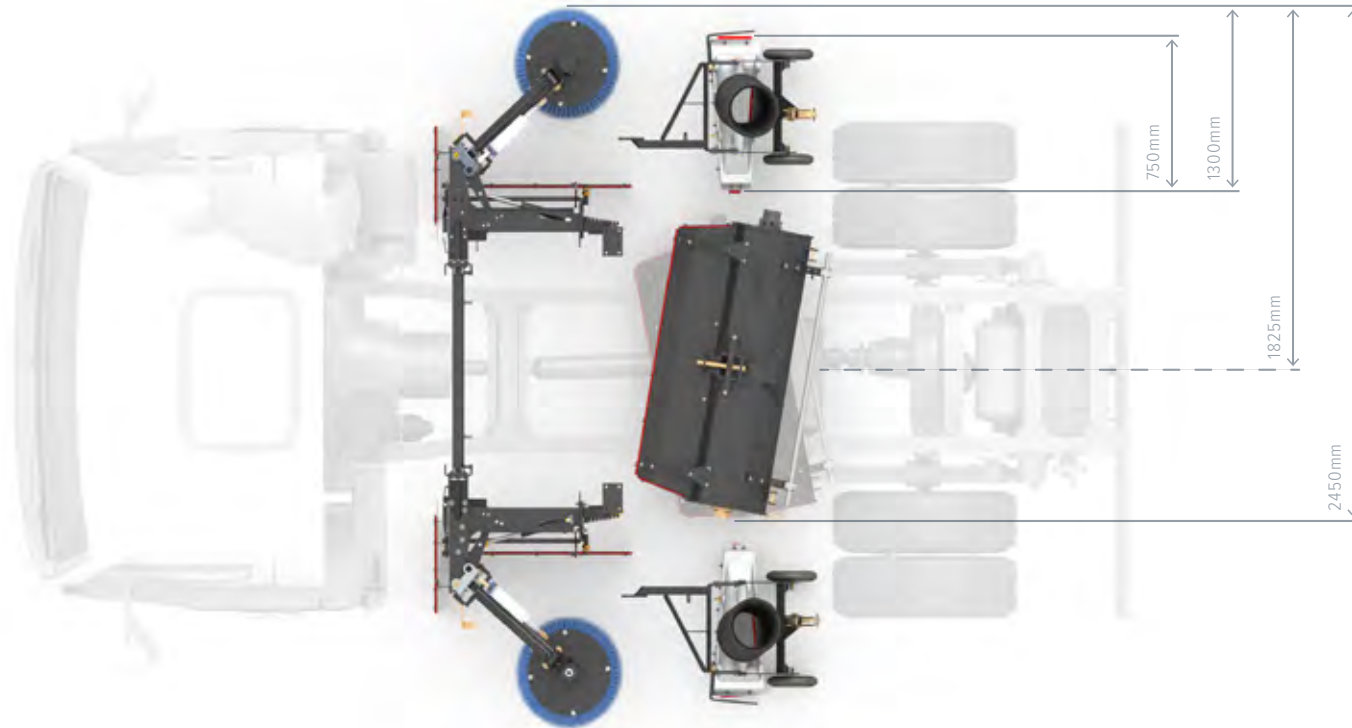

Side Brush

The side brush equipment is of a heavy-duty construction, and has brush speed control with 'power-down' ground pressure regulation fitted as standard. The 'power-down' feature enables the operator to scrub the road harder to remove run-in and compacted dirt. The side brushes have fully adjustable sideways positioning and simultaneous side brush rotation operation to ensure you sweep efficiently, even in awkward situations. The S8400 has an impressive overall sweep width of 3650mm and allows the S8400 to clean many roads in a single pass.

Wide Sweep Brush

The 400mm-diameter by 1300mm-long wide sweep brush has a fully adjustable ground pressure regulation system. The system is set on 4 regulators (2 for left hand sweeping and 2 for right hand sweeping). This enables the operator to switch from left to right-hand sweeping operations without the need to leave the cab of the vehicle and readjust the brush. Fitted with 'power-down' the wide sweep brushes performs efficiently on run-in and stubborn compacted dirt. The wide sweep brush canopy and guards are robustly constructed from 4mm powder-primed and powder coated mild steel ensuring maximum life expectancy.

Opposed Sweep Function

With one-touch operation, the wide sweep brush can be switched to push material away from the suction nozzle. This simple innovation improved road planing productivity by up to 60%.

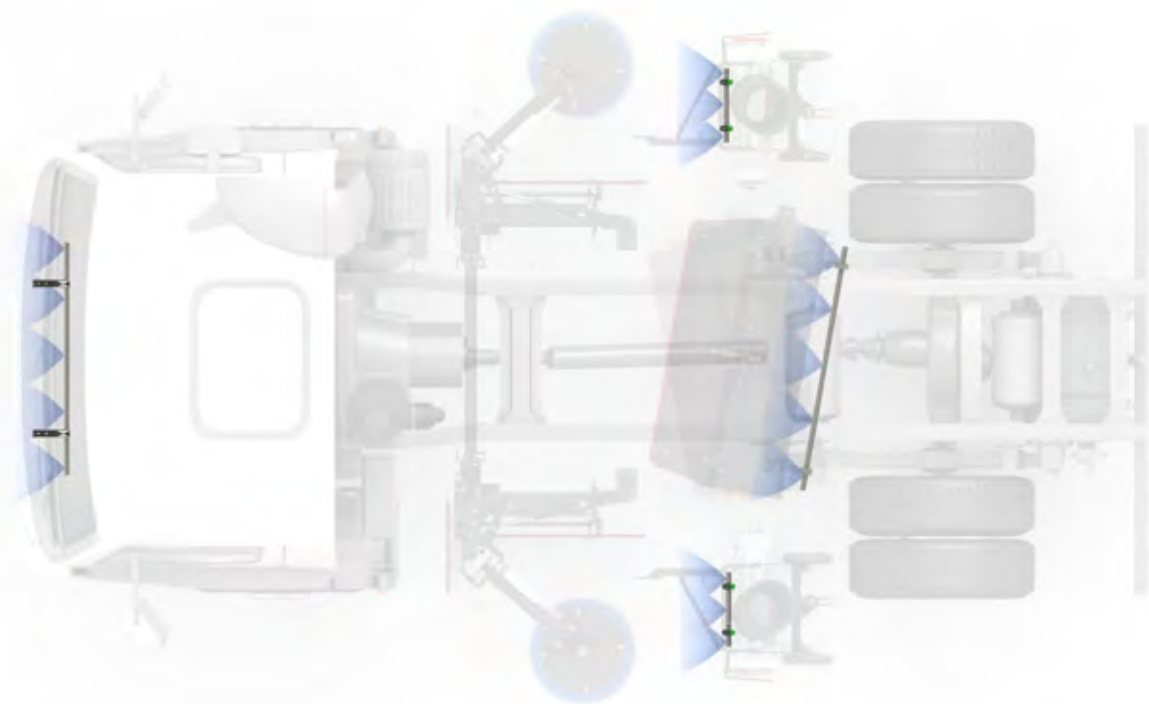

Dust Suppression System

The self-priming, low-pressure water dust suppression pump ensures dust-free collection of all swept material. Water can be injected directly into the suction box, towards the side brush, and across the front of the vehicle. The dust suppression system delivers 35 litres/min at 3.5 bar (50 psi).

High Pressure Wash

For more arduous cleaning the high pressure water system incorporates a hand lance with 15 metres of hose, suction box spray bars, and wide sweep brush spray bar all delivering water at up to 30 litres/min at 150 bar (2,200 psi) precisely where it's needed.



Nozzle Suction

The suction boxes are constructed of cast aluminium with a 4mm moulded vulcanized wear-resistant rubber lining. Each of the two boxes can be raised or lowered, and be tilted backwards at the flick of a switch, to make the pick-up of larger material effortless.

Overhead Suction

The overhead wander hose has a 4.2 metre reach that can be used for many operations; from cleaning catch-pits and road gullies, to picking litter and leaf collection. To ensure the wander hose does not become too heavy in operation, it is fitted with a counter-balancing spring system.

Screen Shakers 'Healthy Airflow'

Rear mesh screen shakers are another standard fitment. They enable the operator to clean the rear screens every time the rear door is opened both screens are lowered automatically making thorough washing of the screens an easy task. This is essential to maximise the sweepers suction and will minimise unnecessary engine and equipment wear. The screens can also be operated with the rear door closed using the 'quick clean' function. This is done by unclipping the handle and pulling down sharply on the rear cables to shake the screens free from dirt and leaf build-up while away from tip access.



CANbus Operating System

The S8400's equipment is activated via an operator's electronic CANbus control panel, which has been designed and installed with operator ergonomics in mind. The easy-to-use panel allows the operator to set their preferred settings, which are then activated by one-touch operation on the iSweep system, mounted near the driver's door.

iSweep

This smaller touch sensitive control panel is conveniently mounted near the operator's side window, helping to reduce the level of distraction to the operator to an absolute minimum. Full control simply rests at the operators finger tips.

'TEMPEST' LEAF BLOWER



Leaf Blowing System

Our patented leaf blowing system is the most effective method of removing leaves in rural/semi-rural conditions. It blows leaves off roads and footpaths into verges in one pass, by cleverly using the sweeper vacuum exhaust air, blowing it out from under the front of the chassis cab. Full electric control allows you to adjust the air jet angle to right where you need it. It reduces non-productive off-site time and has considerable fuel and environmental savings by eliminating needless journeys to landfill sites.

Leaf Blowing System - Wander Hose

The hand blowing wander hose attachment reaches into corners and difficult areas where leaves cannot be blown away. The handheld blower attachment enables the operator to blow them into the road, where they can be swept up conventionally by the sweeper.



CUSTOMER SUPPORT

We understand and deliver what you need

We pride ourselves in understanding our customers' service requirements. Having owned and operated our own road sweeper hire fleet for many years, we know exactly what kind of support is essential to meet our customers' demands.

Our highly trained team will work with you to identify potential issues, offering fast and cost-effective solutions, to ensure that your equipment is running reliably and accurately for the maximum time possible.

For customer support, contact our Customer Support Centre on **0845 203 6400** or info@stockswepers.com



PARTS DEPARTMENT

Parts

We have a dedicated, fully stocked parts warehouse based in the UK.

95% of our sweeper parts are kept in stock and can be delivered to you in the mainland UK the next working day.

Our parts department supplies parts for most brands of sweepers. We supply internationally, to over 20 countries around the world. For more information on parts for your specific machines, please get in touch today.

Contact our Parts Department on 0845 203 6400 or parts@stockswepers.com

Every effort has been made to ensure that the information contained in this brochure is correct.
Due to continuous product development, we reserve the right to make alterations/improvements without prior notice. E&OE.
© Stock Sweepers LTD 2015



facebook.com/stockswEEPERS



twitter.com/stockswEEPERS



google.com/+stockswEEPERS



instagram.com/stockswEEPERS



youtube.com/stockswEEPERS

www.stockswEEPERS.com
info@stockswEEPERS.com

t: +44 (0) 845 203 6400
f: +44 (0) 845 203 8400

Stock Sweepers LTD
Building 13
Vantage Point Business Village
Mitcheldean
Gloucestershire
GL17 0DD
United Kingdom